

READ BEFORE USING

**FlexHD® Structural
and
FlexHD® Structural Diamond
Acellular Dermis
DONATED HUMAN TISSUE**

CAUTION: TISSUE IS FOR SINGLE PATIENT USE ONLY. Aseptically Processed. Passes USP <71> Sterility Tests. FlexHD Structural Is Not Terminally Sterilized. Do Not Sterilize.

THIS TISSUE WAS RECOVERED FROM A DECEASED DONOR FROM WHOM LEGAL AUTHORIZATION OR CONSENT HAS BEEN OBTAINED. THIS RECOVERY WAS PERFORMED USING ASEPTIC TECHNIQUES. PROCESSING AND PACKAGING WERE PERFORMED UNDER ASEPTIC CONDITIONS. TERMINAL STERILIZATION AGENTS WERE NOT USED IN THE PROCESS.

DESCRIPTION AND INDICATIONS FOR USE

FlexHD Structural is human allograft skin minimally processed to remove epidermal and dermal cells and is packaged in an ethanol solution. The process utilized preserves the extracellular matrix of the dermis with the intent to address the issues of the specific and non-specific inflammatory response. FlexHD Structural Diamond is a specially shaped FlexHD Structural.

Flex HD Structural is used for the replacement of damaged or inadequate integumental tissue or for the repair, reinforcement or supplemental support of soft tissue defects.

CAUTIONS AND WARNINGS FOR USE

Do not sterilize. Do not freeze. Trace amounts of Chlorhexidine, Peracetic Acid, Ethanol and Propylene Glycol may be present. FlexHD Structural is packaged in an ethanol solution and should be rinsed in a sterile solution prior to implantation. Care should be taken when using FlexHD Structural in conjunction with electrical equipment. NOTE: No antibiotics were used in the manufacturing process.

Extensive medical screening procedures have been used in the selection of all tissue donors for MTF (please see Donor Screening & Testing Section). Transmission of infectious diseases may occur despite careful donor selection and laboratory testing, including serology and nucleic acid testing (NAT). Bacterial infection at the site of grafting may occur.

PRECAUTIONS

Conditions that potentially inhibit the integration of Flex HD Structural include, but are not limited to:

- Uncontrolled diabetes
- Low vascularity of the surrounding tissue
- Local or systemic infection
- Dehiscence and/or necrosis due to poor revascularization
- Inability to cooperate with and/or comprehend post-operative instructions

ADVERSE EFFECTS

Possible adverse effects of using human skin include but are not limited to:

- Local or systemic infection
- Failure of integration into the surrounding tissue
- Specific or non-specific immune response to some component of the graft

Within the United States: Adverse outcomes attributable to the tissue must be promptly reported to MTF. Outside of the United States: Adverse outcomes attributable to the tissue must be promptly reported to your local representative.

ALLOGRAFT INFORMATION

FlexHD Structural is composed of an acellular dermal matrix. During tissue processing and packaging, this allograft was tested and showed no evidence of microbial growth, complying with the requirements of USP <71> Sterility Tests. In addition, this allograft was tested and met an MTF standards for an acceptable Endotoxin Limit. **Do not subject allograft to additional sterilization procedures.**

Dispose of excess or unused tissue and all packaging that has been in contact with the tissue in accordance with recognized procedures for discarding regulated medical waste materials.

INSTRUCTIONS FOR USE

FlexHD Structural is packaged in a sterilized foil pouch that is designed to be passed directly into the sterile field.

Employ best practices with aseptic “no touch” technique when handling FlexHD, including minimizing direct handling of FlexHD until ready to implant and ensuring frequent glove changes.

1. Peel back the outer Tyvek Package and pass the inner foil pouch to the sterile field.
2. In preparation for surgery with FlexHD, remove the graft from the package and place it in sterile solution.
3. Following the initial soak, transfer FlexHD to an antibiotic solution until ready for implantation.
4. Once the tissue has been removed from the inner pouch, discard the pouch and packaging solution outside of the sterile field and away from electrosurgical equipment.
5. FlexHD Structural may be aseptically trimmed to fit the dimensions of the application site. The tissue can be shaped with scissors or scalpel, per the surgeon’s preference. At this point the FlexHD Structural is ready for application in the surgical site.

Note: Concentration of antibiotic solutions should be less than normally indicated for I.V. administration. Toxicity and patient sensitivity to any antibiotics should be verified prior to use.

Orientation

In order to discern the dermal side from the epidermal side, note that in most instances the epidermal side may have more pigmentation than the dermal side. For further verification, add a drop of blood to both sides of the graft and rinse with sterile saline. The dermal side will appear red and the epidermal side will appear pink.

To ensure proper orientation of FlexHD Structural, position it so that the indicating notch is in the upper left-hand side of the tissue, facing left. This will assure that the epidermal side is facing up.

STORAGE

FlexHD Structural should be stored at ambient temperature. No refrigeration or freezing is required. It is the responsibility of the transplant facility or clinician to maintain the tissue intended for transplantation in the appropriate recommended storage conditions prior to transplant.

DONOR SCREENING & TESTING

Prior to donation, the donor’s medical/social history is screened for medical conditions or disease processes that would contraindicate the donation of tissues in accordance with current policies and procedures approved by the MTF Medical Board of Trustees.

Donor blood samples taken at the time of recovery were tested by a facility that is CLIA certified and registered with the FDA. The donor blood samples were tested for:

- Hepatitis B virus (HBV) surface antigen
- HBV core antibody
- Hepatitis C virus (HCV) antibody
- HIV-1/2 antibody
- Syphilis
- HIV-1 NAT
- HCV NAT
- HBV NAT

Additional testing of SARS-CoV-2 virus, HTLV I & II and/or West Nile Virus (as applicable) may also have been performed. All infectious disease test results passed acceptability for screening. This allograft tissue has been determined to be suitable for transplantation.

The infectious disease test results, consent, current donor medical history interview, physical assessment, available relevant medical records to include

previous medical history, laboratory test results, autopsy and coroner reports, if performed, and information obtained from any source or records which may pertain to donor suitability, have been evaluated by an MTF physician and are sufficient to indicate that donor suitability criteria current at the time of procurement, have been met. This tissue is suitable for transplantation. The donor suitability criteria used to screen this donor are in compliance with the FDA regulations published in 21 CFR Part 1271 Human Cells, Tissues, and Cellular and Tissue Based Products, as applicable. All procedures for donor screening, serologic and microbiologic testing meet or exceed current standards established by the American Association of Tissue Banks

PACKAGING & LABELING

FlexHD Structural is aseptically packaged in a sterilized hermetically sealed foil pouch. The foil pouch containing FlexHD Structural is inside a sealed sterilized Tyvek pouch. The Tyvek pouch is sealed, labeled and then placed inside an envelope. This allograft must not be used under any of the following circumstances:

- If the pouch seal is damaged or not intact or has any physical damage;
- If the pouch label or identifying bar code is severely damaged, not legible or is missing; or
- If the expiration date shown on the pouch label has passed.

Once a pouch seal has been compromised, the tissue shall be either transplanted, if appropriate, or otherwise discarded.

PATIENT RECORD

Tissue recipient records must be maintained by the consignee and transplant facility for the purpose of tracing tissue post transplantation. A TissueTrace® Tracking Form and peel-off stickers have been included with each package of tissue. Please record the patient ID, name and address of the transplant facility, allograft tissue information (using the peel-off stickers) and comments regarding the use of the tissue on the TissueTrace Tracking Form. Alternately a system for electronic submission may be used and sent to MTFTTC@ScerIS.com. *Within the United States:* Once completed, the bottom page of the form should be returned to MTF using the self-addressed mailer. Copies of this information should be retained by the transplant facility for future reference. *Outside of the United States:* Once completed, the bottom page of the form should be returned to the local allograft representative or provider. Copies of this information should be retained by the hospital for future reference.

Reference: Current MTF policies and procedures are in compliance with current FDA, AATB and other regulatory requirements.

Note: Not all tissue forms are available for International distribution.

Definitions of Label Symbols



See IFU



Do Not Reuse

For Translations of Instructions for Use



www.mtfbiologics.org



Processed by: Musculoskeletal Transplant Foundation
 125 May Street, Edison, NJ 08837, USA
 Within the United States: 800.433.6576
 Outside of the United States: +1.732.661.0202

All recovery, processing and distribution costs were paid for by MTF, a non-profit organization

CAUTION: Restricted to use by a physician and/or podiatrist.

MTF tissue forms and products are protected by one or more issued or licensed technologies which may be found on the MTF website www.mtfbiologics.org. MTF Musculoskeletal Transplant Foundation®, MTF Biologics®, Tissue Trace®, and FlexHD® are registered trademarks of the Musculoskeletal Transplant Foundation, Edison, NJ USA.

©2020 Musculoskeletal Transplant Foundation
 CTO: 100024

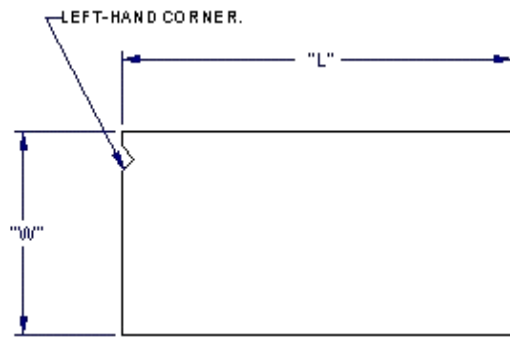

FlexHD Structural

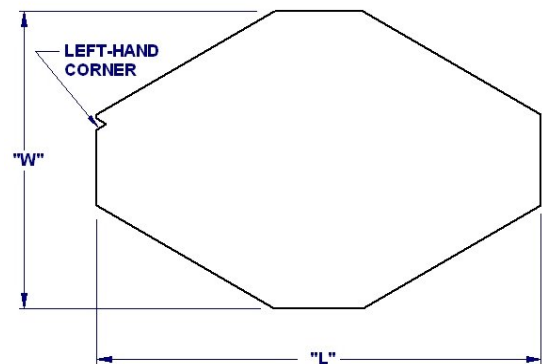

FlexHD Structural Diamond